

# 24136—80

Pipe-line fastening parts.  
Four-seat cramps.  
Design and dimensions

16690—71

12 8001

1980 . 1891

25 »

1985 .

16.10.85 3332

- 01 01.8

01.01.9f

1.

*D* 4 50 .

2.

-

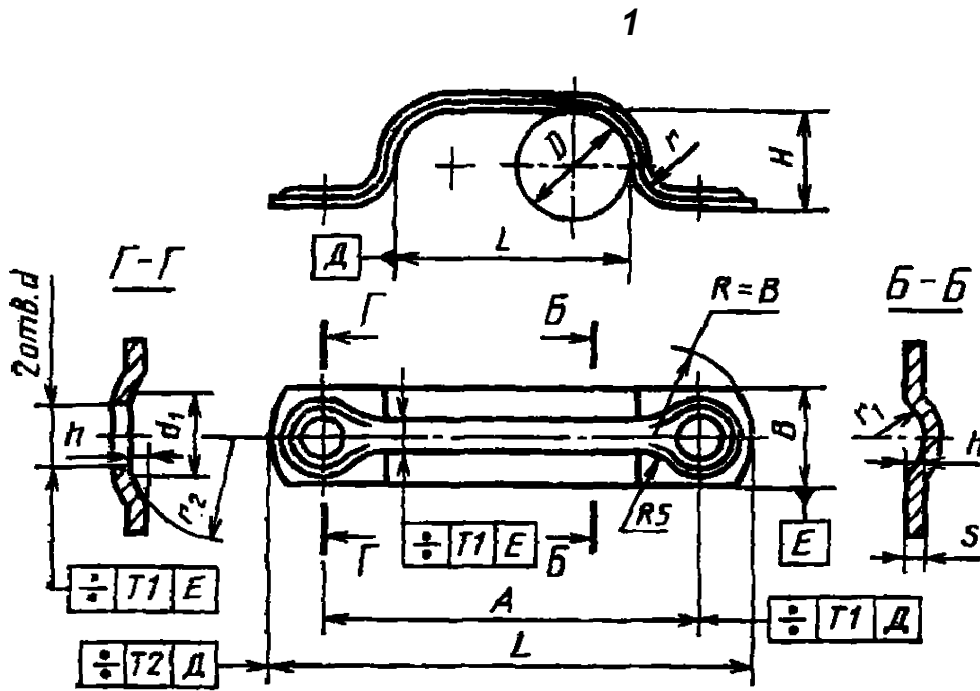

Исполнение 2

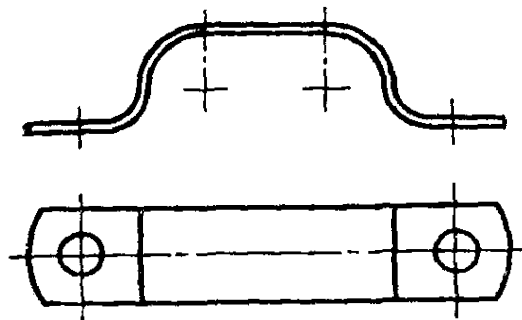

1. :  
2. ,  
R s,  
1 .

D	±0,5	BXS		L	d <sub>14</sub>	dy	h	l		r	f2	1000 "		*			
		1	2					%	а 5*			1	2	1	2		
4	34	16X1,0	16X2	3	50	5,8	9	1,0	16	0,6	3	2	10	6,2	12,4		
5	37			4	53				20					6,7	13		
6	44			5	60				24					7,5	15,0		
.8	50			6	66				32					8,5	17,0		
J0	58			8	74				40					10,1	20,2		
12	66			10	82				48					11,5	23,0		

D	±0.5	BXS		L	d <sub>14</sub>	d,	h	l		v	1000		*	
		1	2					/	2		1	2		
14	80	18X1,6	18X3	12	98	7,0	10	56	0,6	5	3	10	24,9	46,6
16	88			14	106			64					27,4	51,2
18	96			16	114			72					29,9	55,9
20	110			18	128			85					33,8	63,2
22	125	22X1,6	22X3	20	147	9,0	14	90	1,0	6	4	16	46,7	87,3
25	140			22	162			105					51,8	96,9
28	150			24	172			115					55,3	103,4
32	165			28	187			130					61,1	114,2
36	180			32	202			145					66,8	124,9
40	200			35	230			165					129,8	194,7
45	220	30X2,0	30X3	40	250	2,0	2,0	185	1,0	6	4	16	142,1	213,1
50	240			45	270			205					156,0	234,0

1 D = 20

20

9. :

1—20—20— 9.

24136—80

2

12 18 10

2—20—12 18 — . .

24136—80

3.

— 24140—80.